



T-Series QuickStart Guide

PPT Publication # 843-0102 (Rev S)

About this guide

Thank you for using PPT's T-Series™ camera. This guide provides diagrams and a brief overview to help you get started with your new system. This manual covers the entire line of PPT T-Series cameras. Sections that apply to a specific T-Series model number will be indicated. For more detailed instructions, please refer to the Impact Reference Guide and the T-Series Hardware Guide. Please note any cautions and warnings in these manuals.

- Step 1: Unpack and check all the equipment.
- Step 2: Mount the camera (see page 4).
- Step 3: Wire AC power to the power supply and wire the power supply to the vision device power connector (see page 4).
- Step 4: Connect the power connector to the vision device. The power light should turn on.
- Step 5: Connect the Ethernet cable to the camera and the client computer (see page 3).
- Step 6: Configure the client IP address and install Impact Software (see page 2).
- Step 7: Change the camera and client IP addresses and/or masks, if necessary (see page 2).
- Step 8: Connect the I/O cable to the camera and other devices (see page 3).

Unpacking the T-Series camera

Extreme temperature precautions: If your system arrives in very cold or hot weather, allow all the equipment to reach room temperature before plugging it in. Exposing cold equipment to a warm room can cause condensation. If condensation forms, wait for the equipment to dry completely before plugging it in.

Check the shipping cartons for wrinkled or damaged corners, holes through the cardboard, or other signs of rough handling or abuse. Carefully remove the PPT T-Series camera, cabling, and accessories from the shipping package. Place the equipment on a table and inspect each item. Save all packing materials so you can repack the system in case you need to move or ship it.

Camera Operating Specifications

Dimensions	5.43 L x 2.5 W x 1.81 H (inches) 138 x 63.5 x 46 (mm)
Weight	.81 lb. (365.7 grams) 1.03 lb. (467.8 grams) with bracket
Input Power	+24 VDC(+/- 20%) .50 A (min.)
Temperature	-5 to +45 C (+23 to +113 F)
Humidity	20% to 80% (non-condensing)
Optical Characteristics	See page 2

An optional power supply is available for the T-Series camera. If you provide your own, it must be a Listed power supply for the United States and Canada, or a power supply that meets the requirements for use where either IEC 60950 or EN60950 is applicable. It must provide the required input power within the operating specifications listed above.

System Precautions

Follow all warnings and instructions in this guide and in other user manuals shipped with your hardware components.

To avoid damage to your system and its components, never plug or unplug a cable when the power is on. Always disconnect the power supply before making any cable changes.

Never use the system if a power cable has been damaged. Do not allow anything to rest on a power cable. Keep cables away from traffic.

The camera should be firmly mounted to a solid surface to insure sufficient heat transfer away from the camera case. Use the provided bracket or the mounting holes in the case bottom.

Do not expose any part of your system to moisture, rain, or snow, and do not use it near water.

To avoid injury, never open the camera case. Opening the case or removing the tamper-proof sticker will void the product warranty.



Warning: There are no user-serviceable parts inside the PPT T-Series camera. To avoid electrical shock, never open the case.



Avertissement: Il n'y a aucune partie utilisateur-utile à l'intérieur de l'appareil-photo T-Série d'PPT. Pour éviter le choc électrique, n'ouvrez jamais la valise.

Installing Impact Software

A client computer is required to install Impact software and configure the vision device. Refer to the Hardware Guide for client system requirements.

1. You may need to turn off automatic virus checking during install if it causes installation problems.
2. You must have administrator privileges to install Impact software.
3. To be able to communicate, the client and device's IP addresses for the local area connection must be configured. The vision device is shipped with a default IP address of 192.168.0.128 and a default mask of 255.255.255.0. If you need to change the devices' IP address or mask, do so before installation.
4. Insert the Impact software installation CD in the client computer's drive and follow the on-screen instructions.

Changing the device IP Address

1. Connect an Ethernet cable from the client computer to the vision device's Ethernet connector.
2. Start VPM, select the desired device in the device list and click Edit IP Address.
3. Enter the desired IP address and IP mask. Leave the Gateway unchanged. Click OK.
4. When the Reboot Warning is displayed, click OK.
5. You may need to change the client computer's IP mask and address so the device and client can communicate. See the instructions below.

Changing the client IP Address

Windows 7

1. In the Start Menu, select Computer, Network, then click Network and Sharing Center.
2. Under "View your Active Networks," click Local Area Connection.
3. Click Internet Protocol Version 4 in the list, then click Properties.
4. On the Alternate Configuration tab, select User Configured.
5. Enter the desired IP address and Subnet Mask.
6. Click OK to close all the open dialog windows.

Windows Vista

1. In the Start Menu, select Network, then click Network and Sharing Center.
2. For the Local Area Connection, click View Status.
3. Click Internet Protocol Version 4 in the list, then click Properties.
4. On the Alternate Configuration tab, select User Configured.
5. Enter the desired IP address and Subnet Mask.
6. Click OK to close all the open dialog windows.

Windows XP

1. In the Start menu, right click on My Network Places and select Properties.
2. Right click Local Area Connections and select Properties.
3. On the General tab, select Internet Protocol (TCP/IP) and click Properties.
4. On the Alternate Configuration tab, select User Configured.
5. Enter the desired IP address and Subnet Mask.
6. Click OK to close all the open dialog windows.

Serial Cable Layout

Pin	Signal Name	Pin	Signal Name
1	DO NOT USE	4	Signal Ground (GND)
2	Transmit Data (TxD)	5	Received Data (RxD)
3	GND	6	DO NOT USE

6-position modular connector (RJ11) Wire Side

An optional T-Series to PC serial cable is available (Part # 431-0549-xx)

Camera Characteristics

The T-Series is available in the following model series (RA = right angle): T2x-R, T2x-RA, T3x-R, T3x-RA, T3x-S, and T3x-SA. The T2x-R, T3x-R, and T3x-S models are mechanically identical. The T2x-RA, T3x-RA, and T3x-SA models are mechanically identical. The T2x-R and -RA processors runs at 667 MHZ (1330 MIPS) and the T3x-R, -RA, and -S processors run at 800 MHZ (1600 MIPS).

The following minimum Impact software release required: T3x-R, -RA: 8.1.7 or later; T2x-R, -RA: 10.0.1 or later; T3x-S, -SA: 10.0.2 or later. Programming Output 3 on the T3x-R, -RA and T3x-S, -SA: Release 8.4.0 or later.

This list includes both -R and -S models

- T20/30: 60 frames per second (fps); 640 x 480 pixel resolution
- T21/31: 60 fps; 640 x 480 pixel resolution; remote head
- T23/33: 60 fps; 640 x 480 pixel resolution; color imager
- T24/34: 16 fps; 1024 x 768 pixel resolution; color imager
- T25/35: 16 fps; 1024 x 768 pixel resolution
- T27/37: 12 fps; 1600 x 1200 pixel resolution
- T28/38: 12 fps; 1600 x 1200 pixel resolution; color imager

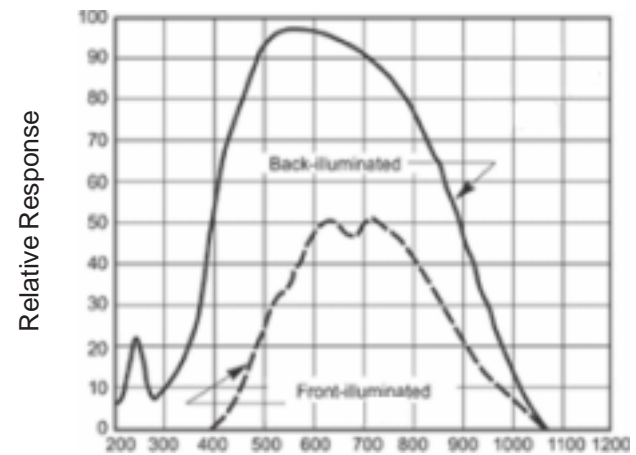

T-Series Spectral Response (excludes lens and light source characteristics)

Resetting the vision device

To reset the vision device, insert the tip of an unfolded paper clip (or similar object without a sharp tip), inside the hole on the rear panel below the power plug (see page 3). Gently press the reset button. Vision programs and data are retained, but the device is put off-line after the reset.

Connection Points

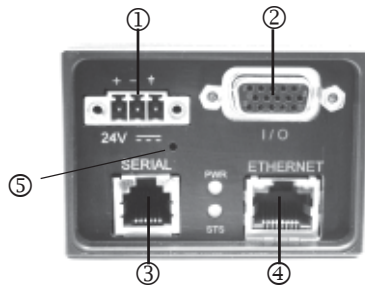

- ① **Power supply** - See Power Supply Cable Layout
- ② **I/O**- Use optional cable (Part # 606-0568-xx) and terminal block (Part # 248-0136). *Do not use a standard VGA video cable.*
- ③ **Serial port** – Use optional serial cable Part # 431-0549-xx or a 6-wire modular connector (RJ-11) with 4-wire cable to connect to another device (e.g. terminal, PLC, motion controller, data recorder). This may require “null modem” wiring. See Serial Cable Layout.
- ④ **Client computer or network** – Use only Cat5e or better Ethernet Cable (Part # 606-0457-x). A crossover cable is not required.
- ⑤ **Reset Button**

Camera Status Lights

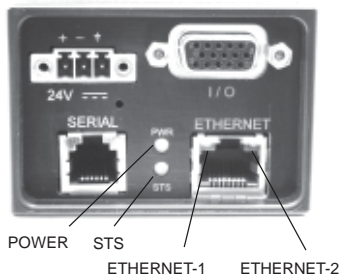

Name	LED State
Power	When 24 VDC power is on, LED is on
STS	<u>Camera Offline</u> LED is off LED blinks during flash memory access
	<u>Camera Online</u> LED is on LED blinks during image and flash memory access
ETHERNET-1	On when ETHERNET link is established
ETHERNET-2	Blinks during data transmission

Strobe Output

Strobe output signals are provided on the camera I/O connector. Pins 3 and 4 provide optically isolated, current-mode signals of 300 mA maximum continuous DC current at 20° C (68° F) – derated at higher temperatures.

Input/Output Cable Layout

WARNING: Output 3 is only available on T2x-R, -RA, T3x-R, -RA, -S and -SA camera models. IF THE MODEL NUMBER DOES NOT CONTAIN -R or -S, MAKING ANY CONNECTIONS TO OUTPUT 3 WILL DAMAGE THE CAMERA.

Pin and Block Terminal Number	Signal Name	Pin and Block Terminal Number	Signal Name
1 2	Trigger In + Trigger In -	10	Do Not Use
3 4	Strobe Output + Strobe Output -	11 12	Input 2 and Event Input + Input 2 and Event Input -
5	Output 3 + NOTE: See Warning	13 14	Output 2 + Output 2 -
6 7	Input 1 and Shift Event + Input 1 and Shift Event -	15	Output 3 - NOTE: See Warning
8 9	Output 1 + Output 1 -		

Do not use a standard VGA video cable for I/O

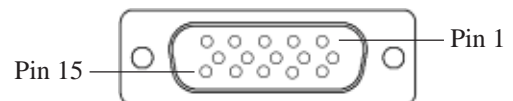

J1 (15 Pin "D" Hi-Density Male)
AMP Part # 748364-1
Part # 244-0158
(Solder Side)

Device Electrical Characteristics

Outputs

Supply Voltage (max)	Turn-on Time	On Current (max)	Off Current (max)	Turn On Delay
26 VDC	250 uS	300 mA	100 uA	50 uS (24 Vdc into 1K-ohm resistive load)

Inputs

Input Current (nominal)	Input Voltage	On Voltage	On Delay	Min On Current	Turn Off Voltage	Turn Off Delay	Max Off Current
3.75 mA @ 12Vdc 5 Ma @ 24 Vdc	0-26 Vdc	>2.8 Vdc	10 uS	2.5 mA	<1.5 Vdc	50 uS	500 uA

Mounting the T-Series In Line Camera

Flat Surface Mounting

The In Line camera should be fastened to a flat, stable, solid surface for camera heat transfer. These dimensions are for flat surface mounting without a bracket.

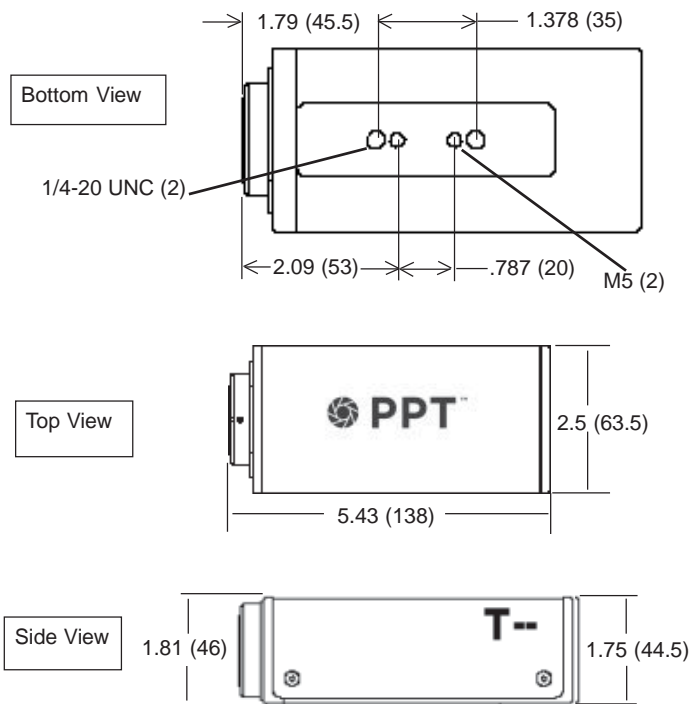

Bracket Mounting

The camera bracket should be fastened to a flat, stable, solid surface for camera heat transfer. These dimensions are for mounting with the bracket (Part # 381-1114).

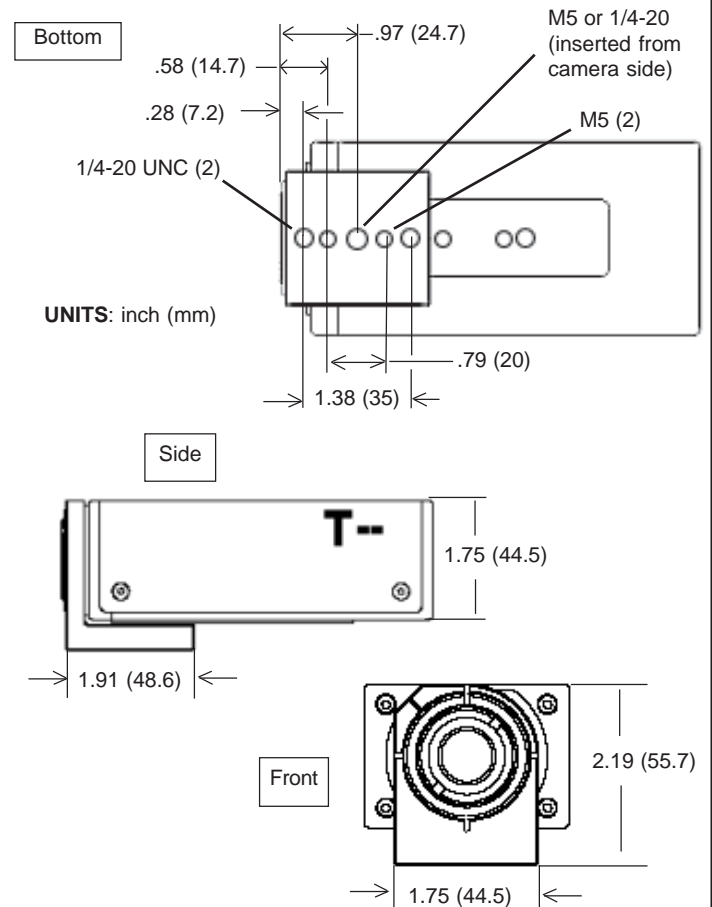

Power Supply Wiring

Optional vision device power supply wiring

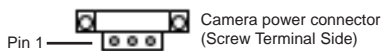

- ① Connect Power Connector Pin 1 to Power Supply +24VDC
- ② Connect Power Connector Pin 2 to Power Supply 24VDC Minus or Ground
- ③ Connect Power Connector Pin 3 to Power Supply Circuit Ground

Pin	Signal Name
1	24 VDC Supply Plus
2	24 VDC Supply Minus or Common
3	Chassis Ground

PPT Vision, Inc. reserves the right to revise this publication from time to time and to make changes in the content hereof without obligation to notify any person of such revision or changes.

Under the copyright laws, neither this publication nor the software may be copied, photocopied, reproduced, or reduced to any electronic medium or machine-readable form, in whole or in part, without the prior written consent of PPT Vision, Inc.

Telephone: 952-996-9500

Facsimile: 952-996-9501

Web site: <http://www.pptvision.com>

E-Mail: support@pptvision.com

Impact, Vision Program Manager, VPM, Control Panel Manager, CPM, Digital Serial Link, T-Series, and DSL are trademarks of PPT Vision, Inc. Microsoft Windows is a trademark of Microsoft Corporation. Java is a trademark of Sun Microsystems, Inc. Copyright © 2005-2012 PPT Vision, Inc. All Rights Reserved

Fastening the Bracket

To fasten the mounting bracket to the T-Series In Line camera:

- Step 1: Remove the lens from the camera body. Turn the mounting screw counterclockwise to loosen the mounting ring.
- Step 2: With the camera body rotated so the image will be correctly oriented when the camera is mounted, place the mounting ring over the front of the camera body. Be sure the mounting block faces the rear of the camera body.
- Step 3: With the ring held tightly against the camera body, turn the mounting screw clockwise to tighten the ring and secure it to the camera. To adjust camera orientation up to five degrees after it is mounted, loosen the screw slightly, rotate the camera body, then tighten the screw.
- Step 4: Secure the mounting block to a rigid surface for proper stability and heat transfer from the camera case.

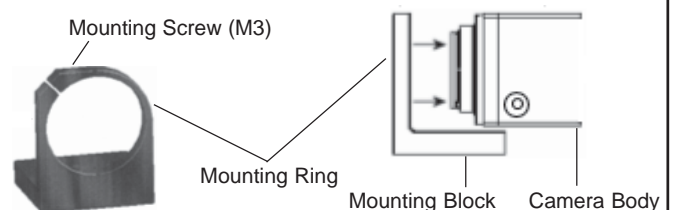

Mounting the T-Series Right Angle Camera

The T-Series camera should be fastened to a flat, stable, solid surface for maximum camera heat transfer.
Here are the mounting dimensions.

UNITS: inch (mm)

