

REVISIONS				
ZONE	REV.	DESCRIPTION	DATE	APPROVED
A		RELEASED	7/16/2007	
B		ADDED 8" & 24" DIMS.	9/19/2007	

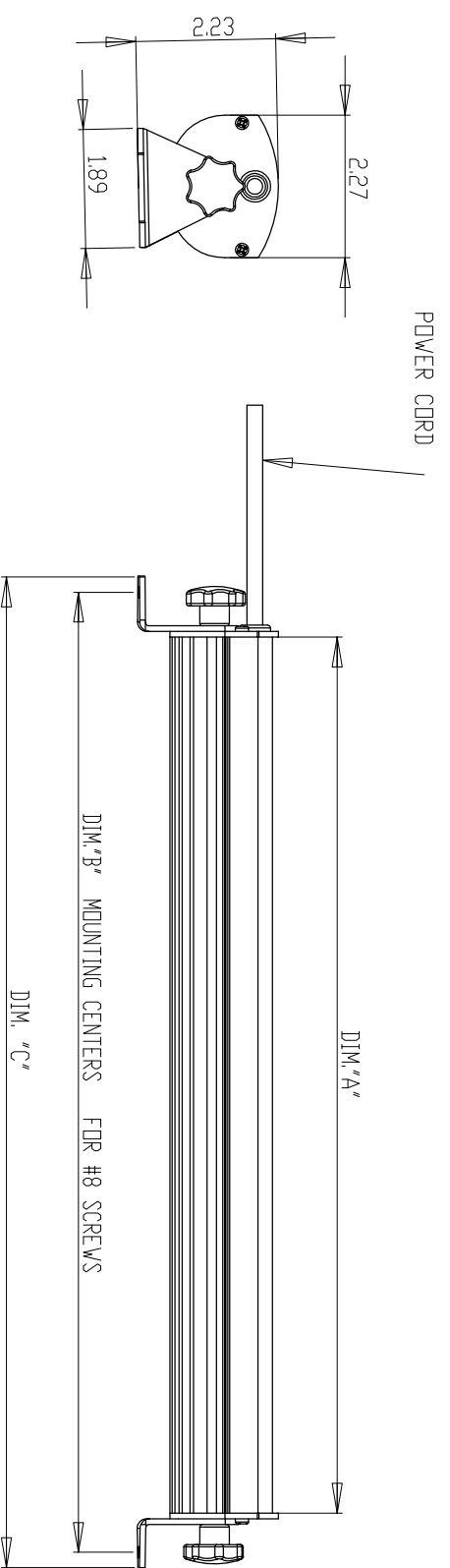

ISOMETRIC VIEW

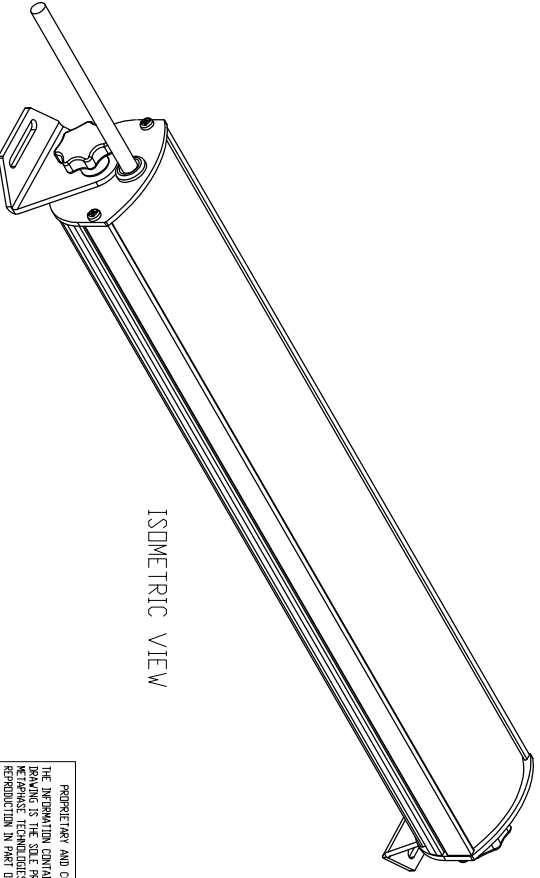

PART NO.	DIM. "A"	DIM. "B"	DIM. "C"
ISD LIGHT 8"	7.81	9.06	9.55
ISD LIGHT 14"	13.93	15.18	15.69
ISD LIGHT 24"	22.81	24.06	24.55

UNLESS OTHERWISE SPECIFIED		DRAWN		DATE	
DIMENSIONS ARE IN INCHES		J.L.		7/07	
TOLERANCES		CHECKED			
FRACTIONAL ±		ENG APPR			
ANGULAR EACH ±		MFG APPR			
HOLE DIA. NOMINAL ±		COMMENTS			
THREAD DIA. NOMINAL ±		O.A.			
INTERPRET GEOMETRIC TOLERANCING PER MATERIAL					
FINISH					
NEXT ASSY USED ON					
APPLICATION		DO NOT SCALE DRAWING			

TITLE: METAPHASE TECHNOLOGIES INC.
 SOLID STATE LED ISD LIGHT ADJUSTABLE SERIES

SIZE DWG. NO. REV B
 SCALE: 1:2 WEIGHT: SHEET 1 OF 1

PROPRIETARY AND CONFIDENTIAL
 THE INFORMATION CONTAINED IN THIS DRAWING IS THE SOLE PROPERTY OF METAPHASE TECHNOLOGIES INC. AND IS TO BE USED FOR THE INTENDED APPLICATION ONLY. REPRODUCTION OR TRANSMISSION WITHOUT THE WRITTEN PERMISSION OF METAPHASE TECHNOLOGIES INC. IS PROHIBITED.