

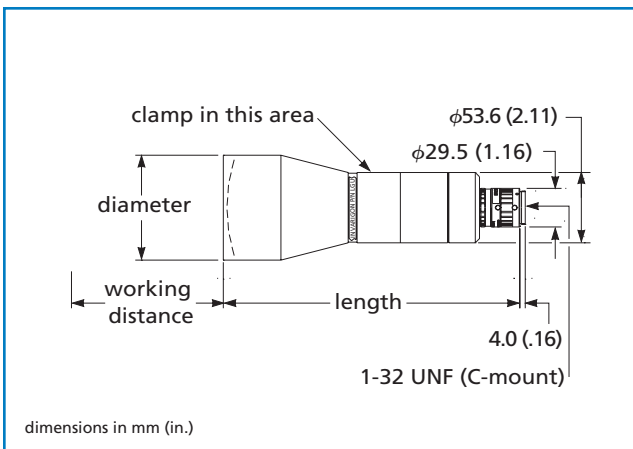

The Invarigon-R™ family of gauging lenses provides telecentric imaging with a wide selection of magnifications. Invarigon-R™ gauging lenses are the most cost-effective choice for critical inspection and metrology imaging applications.

- Telecentric performance (less than 0.2 degrees chief ray angle over the entire object field) allows precise gauging of three-dimensional objects.
- Large selection of magnifications covers most applications.
- Low distortion provides highly accurate images.
- Lockable aperture adjusts to select the required depth of field.
- Fine focus adjustment provides sharper images.
- Rugged single-piece design stands up to harsh industrial environments.
- High-performance multilayer coatings provide the highest image clarity, especially for backlit applications.
- Lens is equipped with a standard C-mount camera interface.



Invarigon-R™ telecentric gauging lens

Invarigon-R™ Telecentric Gauging Lenses

Invarigon-R™ Telecentric Gauging Lenses

Magnification	Working Distance (mm/in.)	Length (mm/in.)	Diameter (mm/in.)	PART NUMBER
0.13 ×	190	217 / 8.5	80 / 3.2	59 LGU 013
0.16 ×	150	176 / 6.9	70 / 2.8	59 LGU 016
0.18 ×	130	154 / 6.1	61 / 2.4	59 LGU 018
0.22 ×	150	170 / 6.7	70 / 2.8	59 LGU 022
0.25 ×	130	148 / 5.8	61 / 2.4	59 LGU 025
0.29 ×	110	126 / 4.9	54 / 2.1	59 LGU 029
0.31 ×	150	171 / 6.7	70 / 2.8	59 LGU 031
0.36 ×	130	149 / 5.9	61 / 2.4	59 LGU 036
0.42 ×	110	126 / 5.0	54 / 2.1	59 LGU 042
0.50 ×	90	105 / 4.1	54 / 2.1	59 LGU 050

APPLICATION NOTE

Telecentricity

A telecentric lens acts as if it has an infinite focal length. An object moved from far away to near the lens goes into and out of sharp focus, but its image size is constant. This property is very important for gauging three-dimensional objects, or objects whose distance from the lens is not known precisely.

Invarigon-R™ Telecentric Gauging Lenses: Optical Characteristics

Magnification (nominal)	Maximum Object Dimensions (mm) ¹			Minimum f/# ²	Minimum Operating f/# ³	Depth of Field (in.) ⁴	PART NUMBER	
	1/3-in. CCD	1/2-in. CCD	2/3-in. CCD				Invarigon-R Lens	Teleconverter
0.13 ×	25.9 × 34.5	34.5 × 46.0	N/A	1.4	4.0	1.66	59 LGU 013	
0.16 ×	20.8 × 27.7	27.7 × 36.8	N/A	1.4	5.6	1.06	59 LGU 016	
0.18 ×	18.0 × 24.1	24.1 × 32.3	N/A	1.4	5.6	0.81	59 LGU 018	
0.22 ×	15.0 × 19.8	19.8 × 26.4	27.2 × 36.3	1.6	8.0	0.54	59 LGU 022	
0.25 ×	13.0 × 17.3	17.3 × 23.1	23.9 × 31.8	1.6	8.0	0.42	59 LGU 025	
0.29 ×	11.2 × 15.0	14.7 × 19.8	20.3 × 27.2	1.6	8.0	0.31	59 LGU 029	
0.31 ×	10.4 × 13.7	13.7 × 18.3	18.8 × 25.1	2.3	8.0	0.27	59 LGU 031	
0.36 ×	9.1 × 11.9	12.2 × 16.0	16.8 × 22.1	2.3	8.0	0.20	59 LGU 036	
0.42 ×	7.9 × 10.4	10.4 × 13.7	14.2 × 18.8	2.3	8.0	0.15	59 LGU 042	
0.47 ×	6.9 × 9.1	9.1 × 12.2	12.4 × 16.8	3.5	11.0	0.12	59 LGU 031	59 LGZ 415 ⁵
0.50 ×	6.6 × 8.6	8.6 × 11.4	11.9 × 15.7	2.3	11.0	0.10	59 LGU 050	
0.54 ×	6.1 × 7.9	8.1 × 10.7	11.2 × 14.7	3.5	11.0	0.09	59 LGU 036	59 LGZ 415 ⁵
0.62 ×	5.3 × 6.9	6.9 × 9.1	9.4 × 12.7	4.6	16.0	0.14	59 LGU 031	59 LGZ 420 ⁵
0.63 ×	5.3 × 6.9	6.9 × 9.1	9.4 × 12.4	3.5	11.0	0.07	59 LGU 042	59 LGZ 415 ⁵
0.72 ×	4.6 × 6.1	6.1 × 8.1	8.4 × 11.2	4.6	16.0	0.10	59 LGU 036	59 LGZ 420 ⁵
0.75 ×	4.3 × 5.8	5.8 × 7.6	7.9 × 10.4	3.5	16.0	0.09	59 LGU 050	59 LGZ 415 ⁵
0.84 ×	4.1 × 5.3	5.3 × 6.9	7.1 × 9.4	4.6	16.0	0.07	59 LGU 042	59 LGZ 420 ⁵
1.00 ×	3.3 × 4.3	4.3 × 5.8	6.1 × 7.9	4.6	22.0	0.05	59 LGU 050	59 LGZ 420 ⁵

¹ The maximum object dimensions shown in the table are 90% of the theoretical maximum dimensions, providing a safety factor for magnification and alignment errors.

² Image-side working f-number with lens aperture fully open. For combinations with teleconverters, the minimum image-side f-number is increased by the teleconverter magnification.

³ Lenses operated at a smaller f-number may show reduced resolution, especially near the edge of the field of view.

⁴ Depth of field is calculated at f/11 for lenses with minimum operating f/# < f/16 (f/22 for all others) and for 30-mm allowable blur at the image (camera) plane.

⁵ Teleconverters cannot be used with certain types of 3-CCD color cameras.

Note: Distortion is less than 1.2% for all lenses. Contact CVI Melles Griot for specific distortion characteristics for a particular lens.